



The Dolomite Centre Ltd.
 Unit 1, Anglian Business Park, Orchard Road,
 Royston, Hertfordshire, SG8 5TW, UK
T: +44 (0)1763 242491
F: +44 (0)1763 246125
E: dolomitesales@syrris.com
W: www.dolomite-centre.com

The Dolomite Centre Limited
 Registered office: 27 Jarman Way,
 Royston, Hertfordshire, SG8 5HW, UK
 Company No. 05640084

INFORMATION SHEET

Part name	Mitos Chip Holder H	Part number	3000155
-----------	---------------------	-------------	---------

Description

The Mitos Chip Holder H works in conjunction with the 4-way Edge connector (part number 3000024), providing fluidic connections to glass microfluidic chips. The chip holder H is compatible with chips of dimensions 22.5 x 15.0 x 4.0 mm. This connection system provides fast and reliable connection between Dolomite chips and 1.6mm tubing.

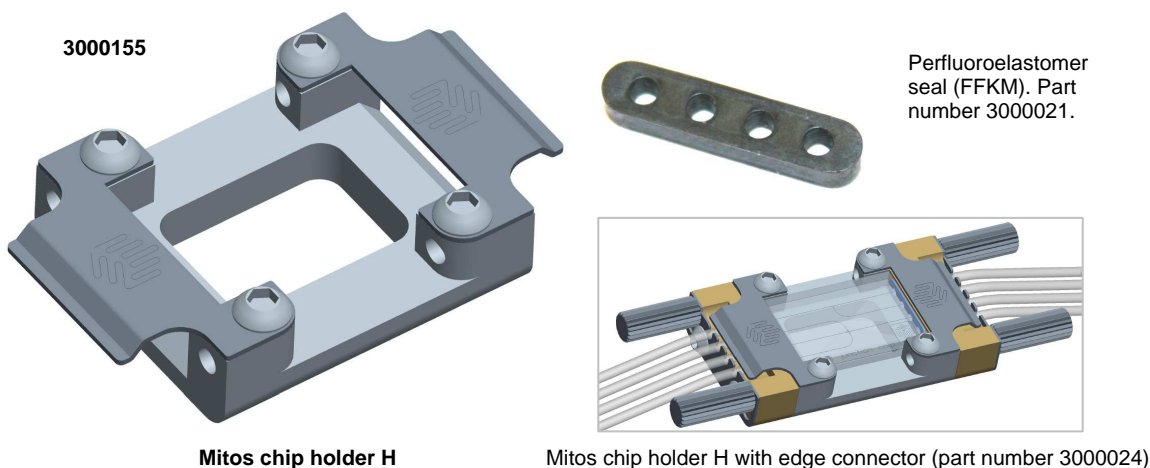

	Chip holder H specification	Value
1	Number of ports	8
2	Chip thickness	4 mm
3	Chip width	15 mm
4	Chip length	22.5 mm
5	Outside diameter of connection tubing	1.6 mm (1/16 inch)
6	Inside diameter of connection tubing	0.25 mm, 0.5 mm, 0.8 mm
7	Connection tubing material	PTFE, FEP
8	Operating pressure	30 Bar
9	Operating temperature range of seal	-15 to 260 °C
10	Wetted materials	Glass, PTFE, and perfluoroelastomer
11	Connector materials	PEEK, Stainless Steel 316
12	Dead volume	< 0.3 µl per port

Cross-sectional view of sealing interface

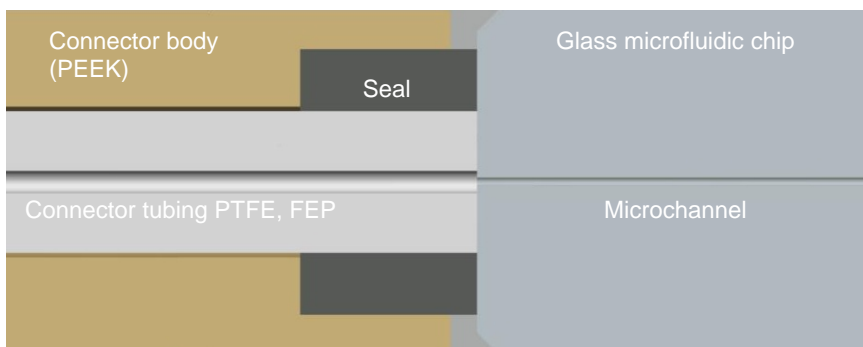

Microfluidic chip with chip holder H geometry (with 15mm long chip)

