

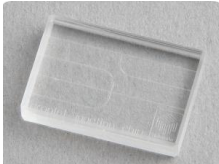

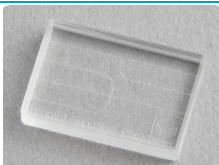

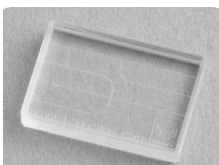

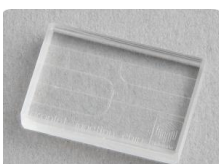
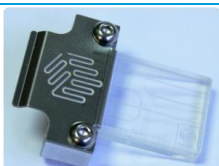

DROPLET CHIPS

USER INSTRUCTIONS

Droplet Chips product range

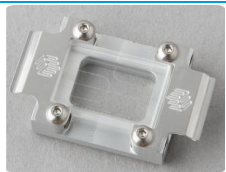
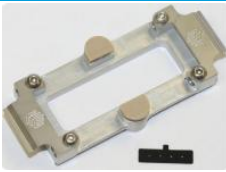
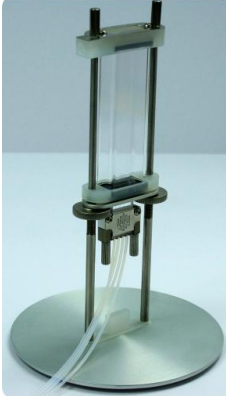
Product name	Product picture	Product description
Droplet Junction Chip (100µm etch depth) (Part No. 3000158)		Glass microfluidic device with T and X-junctions for generating oil-in-water droplets in the size range Ø20 – 150µm. Also available in quartz for improved optical properties (Part No. 3200130).
Droplet Junction Chip (100µm etch depth), hydrophobic (Part No. 3000301)		Glass microfluidic device with T and X-junctions for generating water-in-oil droplets in the size range Ø20 – 150µm. Also available in quartz for improved optical properties (Part No. 3200131).
Droplet Junction Chip (190µm etch depth) (Part No. 3000436)		Glass microfluidic device with T and X-junctions for generating oil-in-water droplets in the size range Ø100 – 300µm. Also available in quartz for improved optical properties (Part No. 3200132).
Droplet Junction Chip (190µm etch depth) hydrophobic (Part No. 3000437)		Glass microfluidic device with T and X-junctions for generating water-in-oil droplets in the size range Ø100 – 300µm. Also available in quartz for improved optical properties (Part No. 3200133).
Droplet Junction Chip with header (100µm etch depth) (Part No. 3200089)		Glass microfluidic device with X-junction for generating oil-in-water droplets in the size range Ø20 – 150µm and ejecting droplets from the chip edge into bulk liquid.
Droplet Junction Chip with header (100µm etch depth) hydrophobic (Part No. 3200090)		Glass microfluidic device with X-junction for generating water-in-oil droplets in the size range Ø20 – 150µm and ejecting droplets from the chip edge into bulk liquid.
Droplet Junction Chip with header (190µm etch depth) (Part No. 3200091)		Glass microfluidic device with X-junction for generating oil-in-water droplets in the size range Ø100 – 300µm and ejecting droplets from the chip edge into bulk liquid.
Droplet Junction Chip with header (190µm etch depth) hydrophobic (Part No. 3200092)		Glass microfluidic device with X-junction for generating water-in-oil droplets in the size range Ø100 – 300µm and ejecting droplets from the chip edge into bulk liquid.

<p>Small Droplet Chip (14µm etch depth) (Part No. 3200136)</p>		<p>Glass microfluidic device with X-junction for generating oil-in-water droplets in the size range 5 – 30µm. Also available in quartz for improved optical properties (Part No. 3200146).</p>
<p>Small Droplet Chip (14µm etch depth) hydrophobic (Part No. 3200137)</p>		<p>Glass microfluidic device with X-junction for generating water-in-oil droplets in the size range 5 – 30µm. Also available in quartz for improved optical properties (Part No. 3200147).</p>
<p>Linear Connector 4-way (Part No. 3000024)</p>		<p>Provides fast and reliable connection between Droplet Chips and 1.6mm OD tubing.</p>
<p>Chip Interface H (Part No. 3000155)</p>		<p>Works in conjunction with the Linear Connector 4-way to provide fluidic connection to the Droplet Junction Chip.</p>
<p>Double Chip Interface H (Part No. 3200088)</p>		<p>Can be used to interface two Droplet Junction Chips together (one hydrophobic and one hydrophilic) for the generation of double emulsions.</p>
<p>Droplet Collection Module (Part No. 3200112)</p>		<p>Allows droplets to be transferred directly from chip to vessel to enable droplets to be collected, treated and analysed. Designed for use with the Droplet Junction Chips with headers.</p>
<p>Top Interface 4-way (4mm) (Part No. 3000109)</p>		<p>Works in conjunction with the Linear Connector 4-way to provide fluidic connection to the Small Droplet Chip.</p>



Contents

1	Chip Connections	5
1.1	Droplet Junction Chip	5
1.2	Droplet Junction Chip with Header	7
1.3	Small Droplet Chip	8
2	System Connections	9
3	Understanding Droplet Formation	11
3.1	Effect of surface properties	11
3.2	Effect of surfactant	11
3.3	Effect of flow rate ratio	12
3.4	Effect of total flow rate	12
4	Chip use and cleaning	13
4.1	Chip use	13
4.2	Chip cleaning	13

1. Chip Connections

The Droplet Chips all require the Linear Connector 4-way (Part No. 3000024) for fluidic connection to 1.6mm OD tubing. Please see the Linear Connector 4-way User Instructions for correct assembly of the tubing into the connector.

1.1 Droplet Junction Chip

The parts required are:

- 2 x Linear Connector 4-way with tubing assembled
- 1 x Chip Interface H

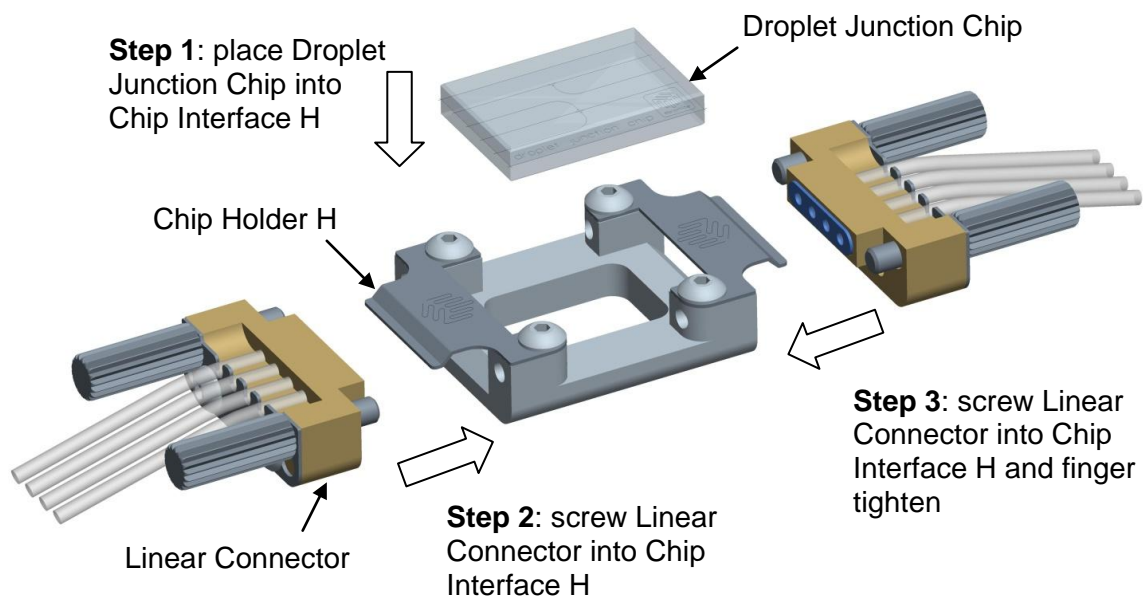

Fluidic connection to the Droplet Junction Chip

With the Droplet Junction Chip, both a T and X-junction are provided, so it is necessary to first decide which junction to use before making fluidic connections. The best junction format will depend on the fluids used. In general the X-junction can provide stable droplet formation at higher flow rates than the T-junction. However, the T-junction may be the best option for stable droplet formation with certain fluids.

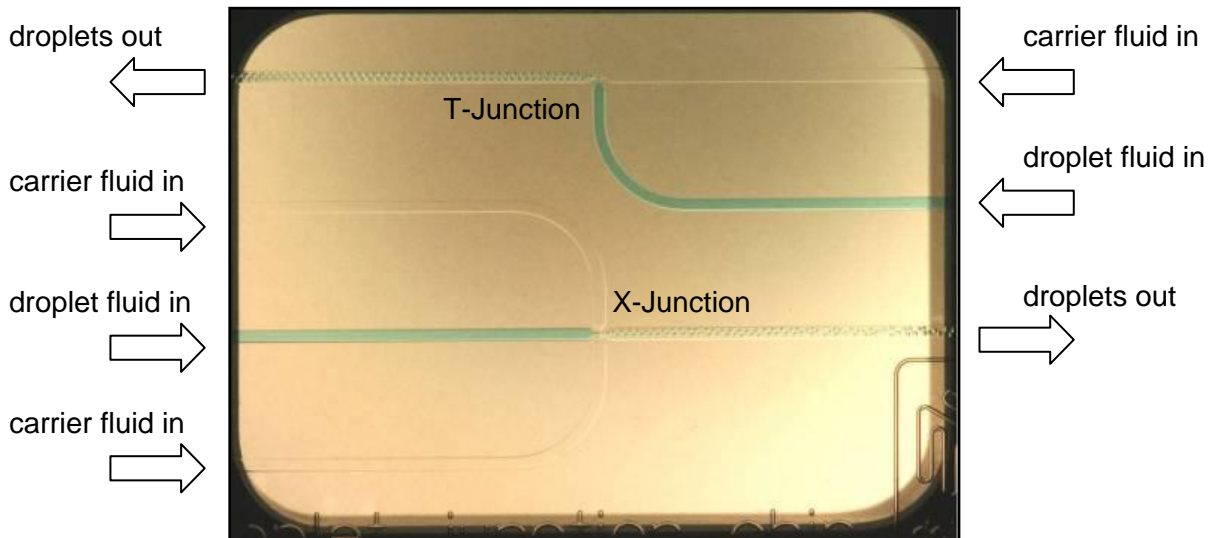

T and X-junctions on the Droplet Junction Chip

When using the X-junction, two equal flows of carrier liquid must be delivered to the junction. The carrier flow can either be split into two streams using a T-connector (Part No. 3000397) or by using the on-chip T-junction. To use the Droplet Junction Chip in this way, the connections shown below should be made. Connect red - red and blue - blue with equal lengths of tubing to ensure equal flow rates of the carrier phase into the X-junction.

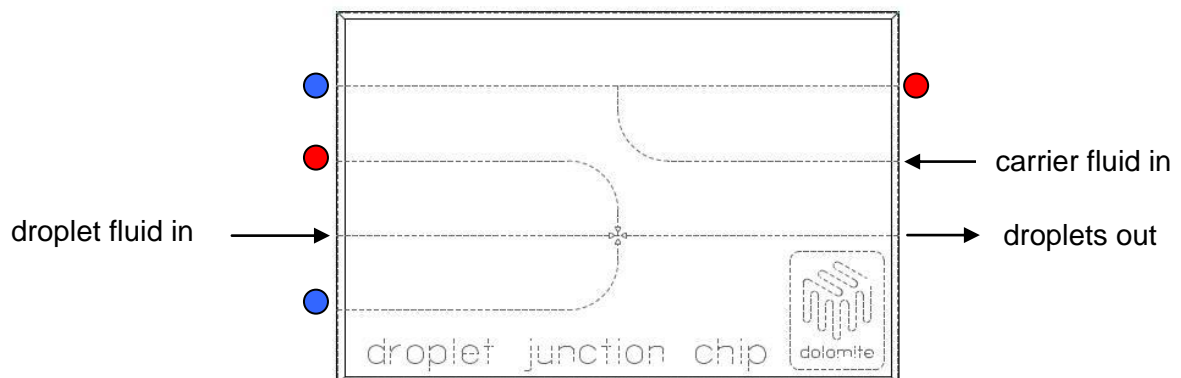

Using the T-junction to split the carrier fluid flow on the Droplet Junction Chip

1.2 Droplet Junction Chip with Header

The parts required are:

- 1 x Linear Connector 4-way with tubing assembled
- 1 x Droplet Junction Module (optional)

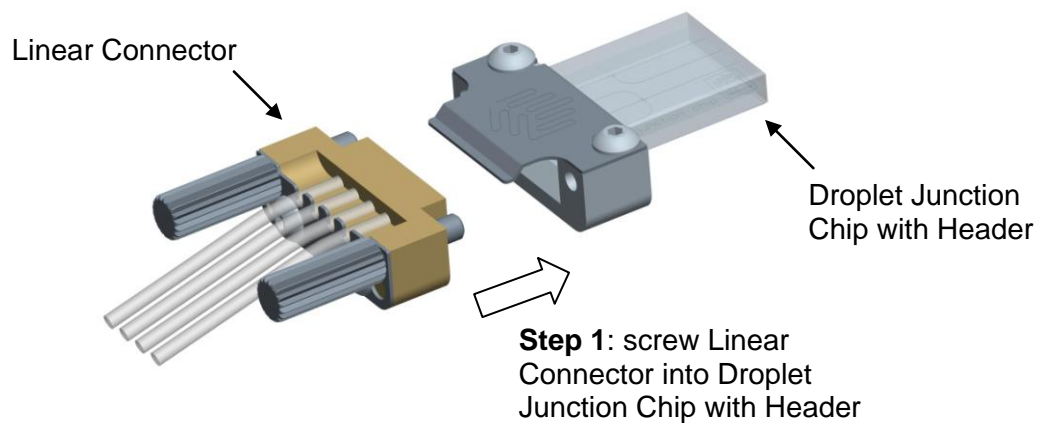

Fluidic connection to the Droplet Junction Chip

The Droplet Junction Chip with Header is designed for ejection of droplets into bulk liquid. Only the X-junction is available for use in this version of the chip. It is compatible with the Droplet Collection Module (Part No. 3200112) for collecting the droplets as they exit the chip. For details on the insertion of the Droplet Junction Chip with Header into the Droplet Collection Module, please see the user instructions for this product.

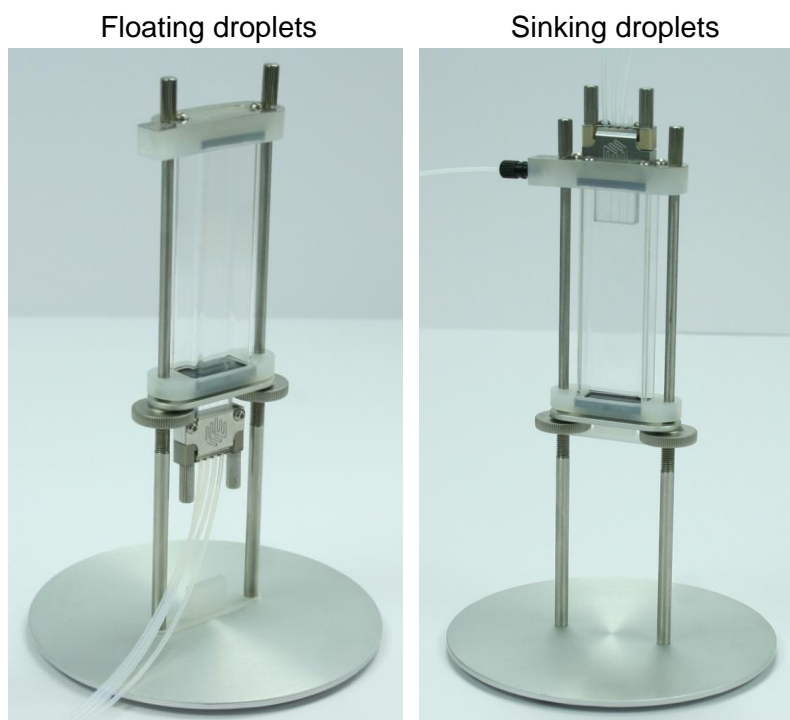

Use of the Droplet Junction Chip with Header with Droplet Collection Module

1.3 Small Droplet Chip

The parts required are:

- 1 x Linear Connector 4-way with tubing assembled
- 1 x Top Interface 4-way

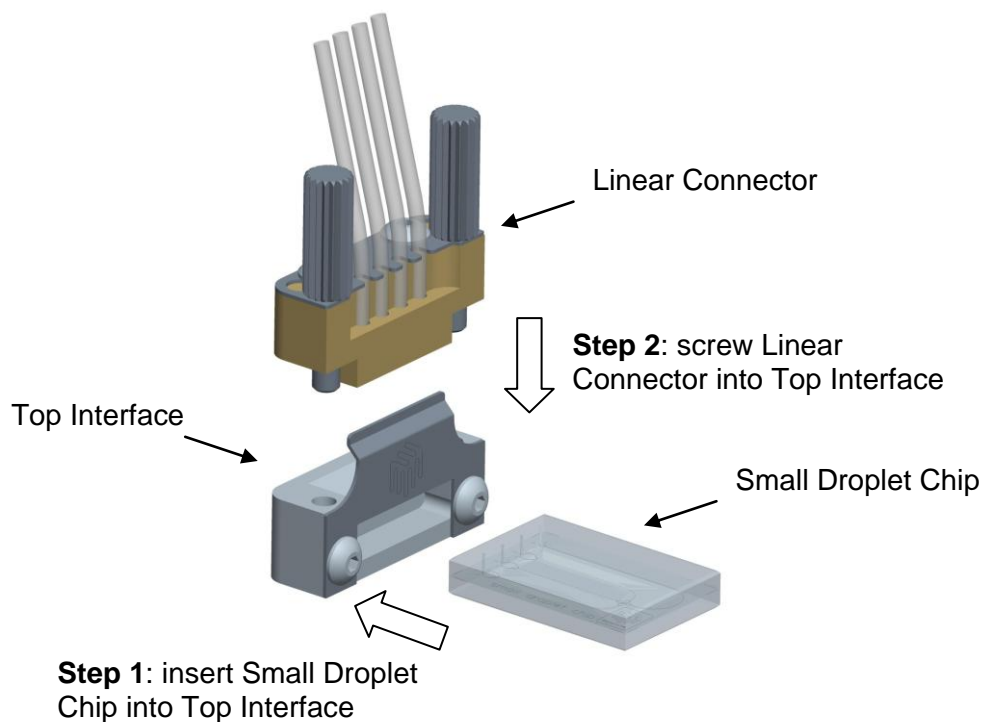

Fluidic connection to the Small Droplet Chip

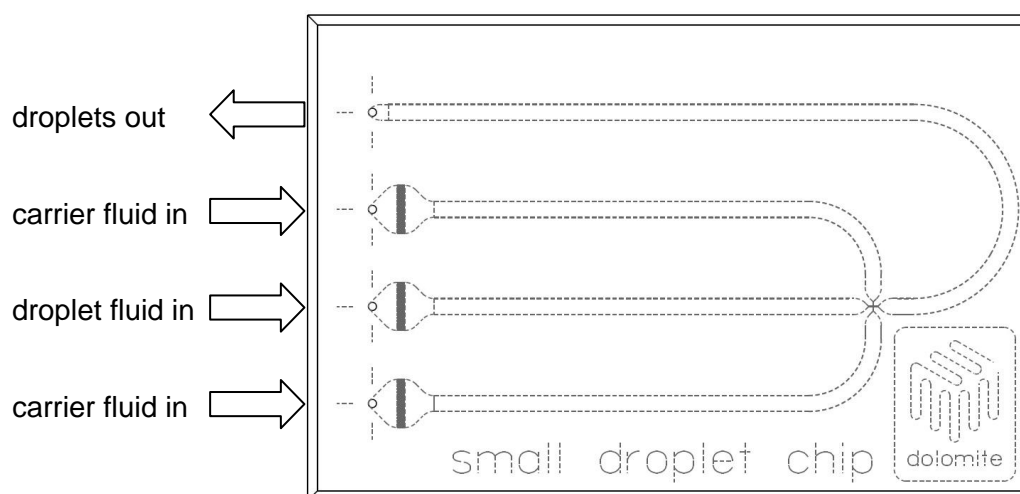

Microchannel layout of the Small Droplet Chip

2 System Connections

For optimum droplet monodispersity (size consistency), it is recommended to use the Mitos P-Pump (Part No. 3200016) and flow resistors in the experimental set-up. The pressure driven pumping mechanism of the Mitos P-Pump is ideal for droplet formation due to its fast response and highly stable flow. With pressure driven pumping, flow resistors are required in the following cases:

- When the flow rate of the connected system is low, a flow resistor is required to enable the user to access low flow rates
- When two or more fluids of different viscosities are pumped into a junction and there is a length of channel downstream, flow resistors are required to prevent flow rate instability due to the varying viscosity in the channel downstream.
- When two or more fluids are pumped into a junction at a high flow rate ratio, flow resistors are required to prevent backflow into the channel with the lower flow rate.

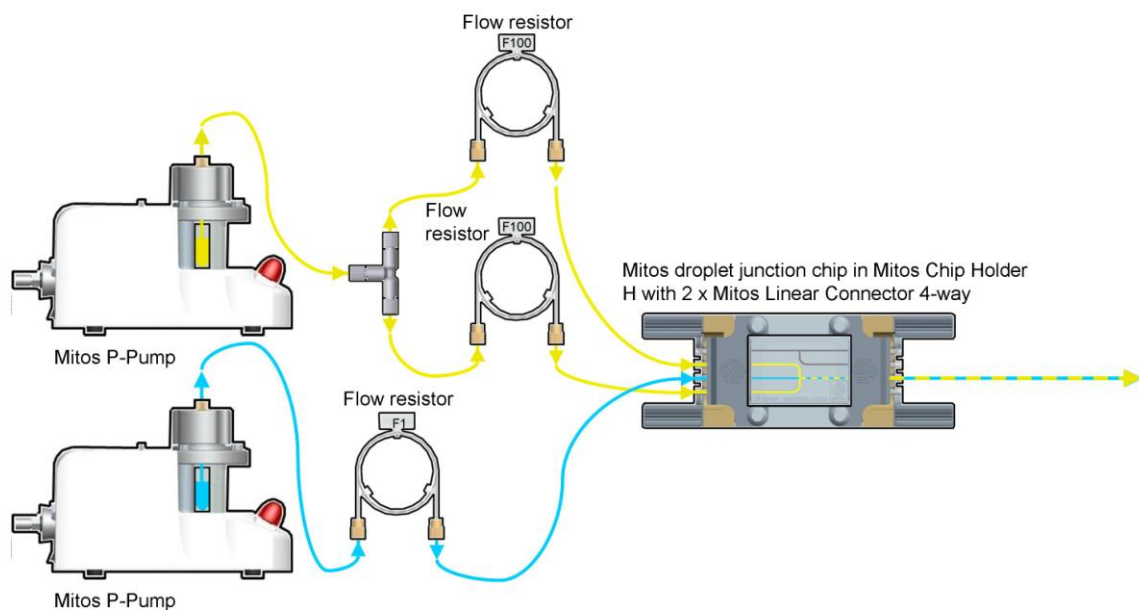

Example system set-up for droplet formation with the Droplet Junction Chip

Dolomite has a broad experience in droplet applications, so please contact us for help configuring a droplet system to fit your requirements.



For droplet formation to occur, the carrier liquid and droplet liquid must be immiscible (normally organic and non-organic). When the carrier liquid and droplet liquid meet at a junction, the carrier liquid is inclined to wet the channel surface and droplets are formed. The size, consistency, and production rate of droplet formation is a function of several physical parameters, including:

- Channel size
- Viscosity and surface tension of the droplet and carrier fluids
- Presence of surfactants
- Miscibility of the droplet and carrier fluids
- Use of hydrophobic or hydrophilic coating on channel walls
- Total flow rate and relative flow rate of each fluid
- Flow stability

3 Understanding Droplet Formation

3.1 Effect of surface properties

The glass channel surface is naturally hydrophilic. This will form organic droplets in an aqueous carrier phase. To form aqueous droplets in an organic phase, a hydrophobic coating is required.

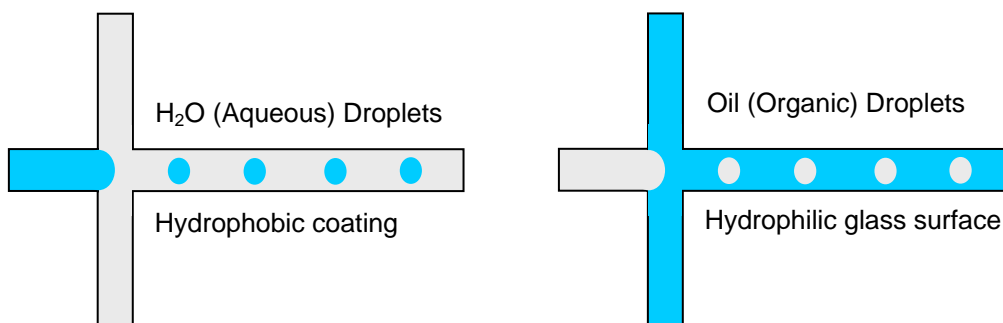

Droplet formation with hydrophilic and hydrophobic surface properties

3.2 Effect of surfactant

A surfactant is a compound that is typically added to the carrier fluid in a low percentage (1 - 5% v/v) to provide a stabilising function. Surfactant molecules have a hydrophilic head and hydrophobic tail, so that they align at the interface between the two fluids. The presence of surfactant molecules provides more consistent droplet formation and prevents coalescence of droplets after formation.

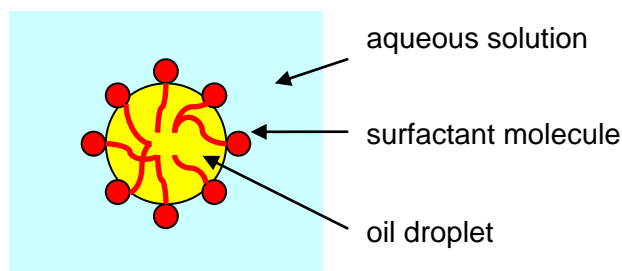

Surfactant molecule with hydrophilic and hydrophobic components

The correct surfactant will depend on the fluids involved, but commonly used surfactants include:

- Span 80: can be added to organic fluids
- SDS (sodium dodecyl sulphate): can be added to aqueous solutions



3.3 Effect of flow rate ratio

The droplet size can be accurately controlled by varying the flow rate ratio between the carrier and droplet fluids. An increase in the carrier flow rate (or decrease in the droplet flow rate) will result in the formation of smaller droplets. A decrease in the carrier flow rate (or increase in the droplet flow rate) will result in the formation of larger droplets. There will be a limit to the highest achievable flow rate ratio, which will depend on the fluids used.

Typical droplets generated using the X-junction on the MitoS Droplet Junction Chip. The organic carrier phase is mineral oil with 1% span and the aqueous phase is H₂O with blue food dye. The droplet sizes are in microns.

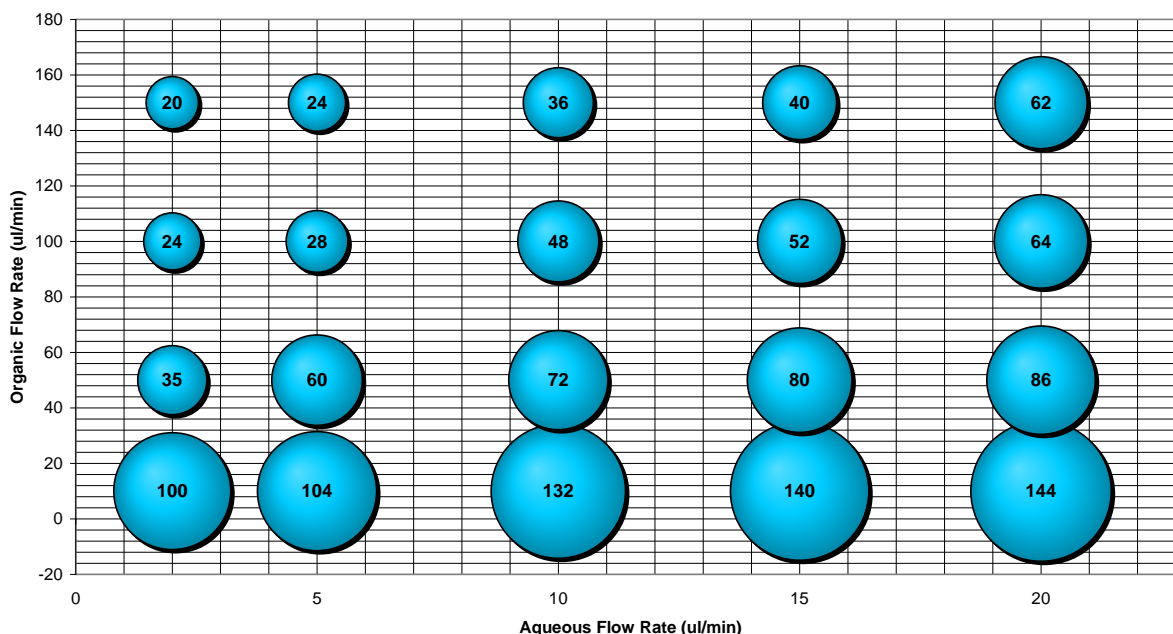

Droplet size chart for the Droplet Junction Chip – 100µm - Hydrophobic

3.4 Effect of total flow rate

As the flow rates of the carrier and droplet fluids are increased, the droplet production rate will increase until a limit is reached. At this point, the two fluids will flow side by side and no droplets will be formed. Droplet production rates over 10,000 per second have been achieved with Dolomite chips.

4 Chip use and cleaning

4.1 Chip Use

Due to the small channel size on many of the Dolomite Droplet Chips, it is necessary to filter all fluids before delivery into the chip. It is also recommended that experimentation should be carried out in a clean environment if possible. The Small Droplet Chip contains on-chip filters on the 3 inlet channels. However, fluids should still be filtered before use to prevent blockage of the filters and prolong chip lifetime.

4.2 Chip Cleaning

The Dolomite Droplet Chips can be cleaned by flushing through with acetone or an alternative organic solvent. Weak acids and bases can also be used to clean the uncoated glass chips, but should not be used on the chips with hydrophobic coating. Over time, acids and bases will remove the hydrophobic coating.

If the microchannel becomes blocked, it may be beneficial to place the chip in a sonication bath for 10 minutes. Please ensure that the chip is removed from the holder to prevent damage to the chip. After sonication, flushing through at high flow rates (e.g. 100 μ l/min) or pressure (30bar) may remove the blockage.



The Dolomite Centre Ltd.

Unit 1, Anglian Business Park, Royston,
Hertfordshire, SG8 5TW, United Kingdom

T: +44 (0)1763 242491

F: +44 (0)1763 246125

E: info@dolomite-microfluidics.com

W: www.dolomite-microfluidics.com

Dolomite Microfluidics

29 Albion Place
Charlestown, MA 02129

F: 617 848 1211

F: 617 500 0136

E: salesus@dolomite-microfluidics.com

W: www.dolomite-microfluidics.com